

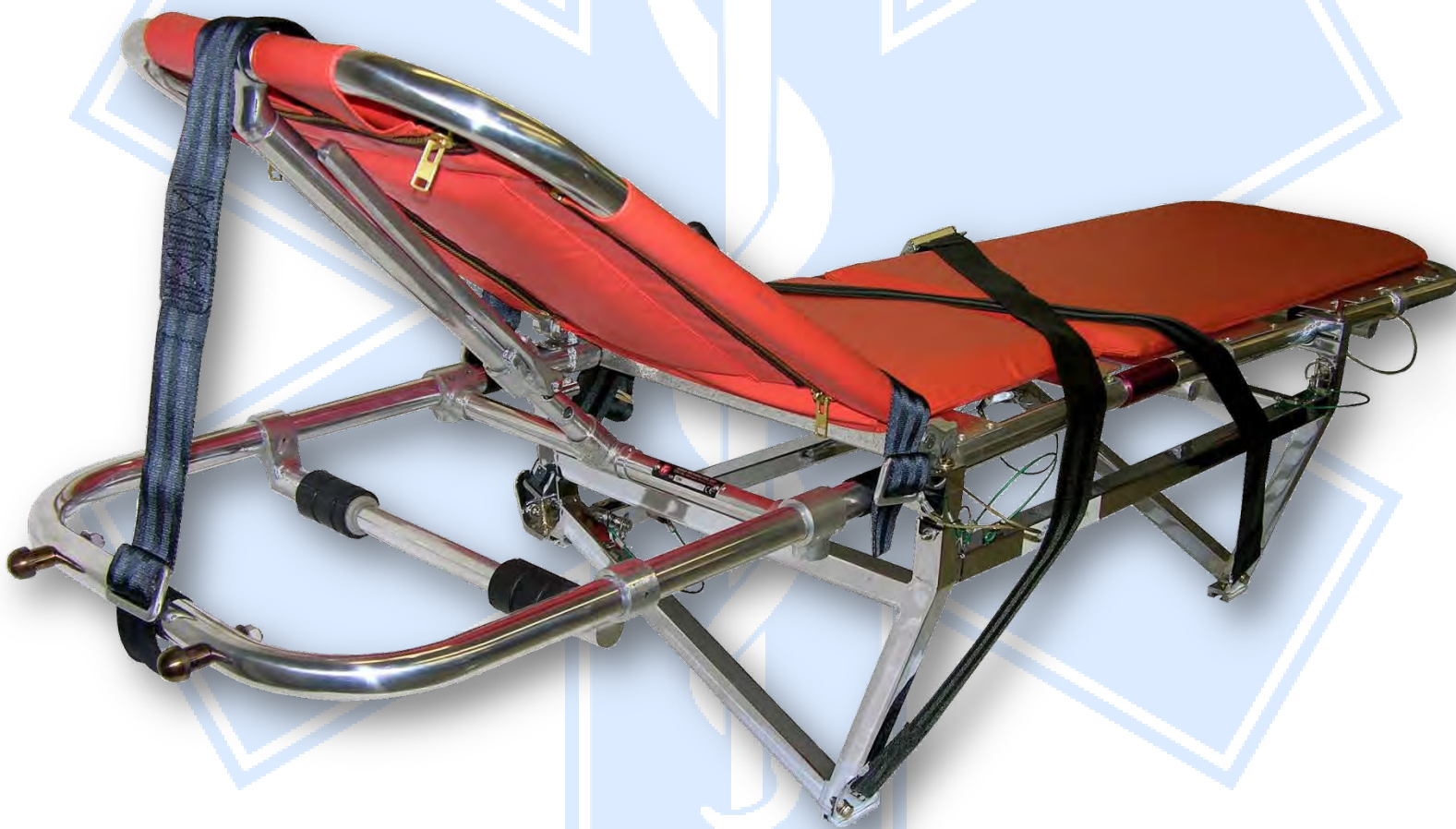

Medical Stretcher & Attendant Seating





Citation 500, 550, 560 Stretcher





Citation 500, 550, 560 Stretcher

Description: The stretcher kit provides a Cessna Citation operator with the option of transporting an ill or non-critical patient. The kit was designed as an economical alternative to complete medevac systems. This unit is ideal for those operators who don't need critical care medical equipment.

Models: Cessna Citation 500, 501, 550, S550, 551, 560

FAA / STC: SA52RM, SA126RM

Approval: Federal Aviation Administration Parts Manufacture Approval, PMA, and Supplemental Type Certificate, STC, (eliminating the need for field approval).

Features: Kit includes stretcher base and cover, portable litter, mattress, mattress cover (conforms to FAR 23.853 horizontal flame test), restraint system, installation instructions, and weight and balance data, etc.

Installation: Initial installation can be accomplished by simply removing the seats on the applicable side of the aircraft and sliding the stretcher on existing seat rails..

Lead Time: Stretchers are normally in stock and available for immediate world-wide shipment, however, fluctuations in demand may cause up to a 30 day delivery delay.





Citation Stretcher



**Line Drawing
with Litter
Detail**

**Fuselage
Reference**

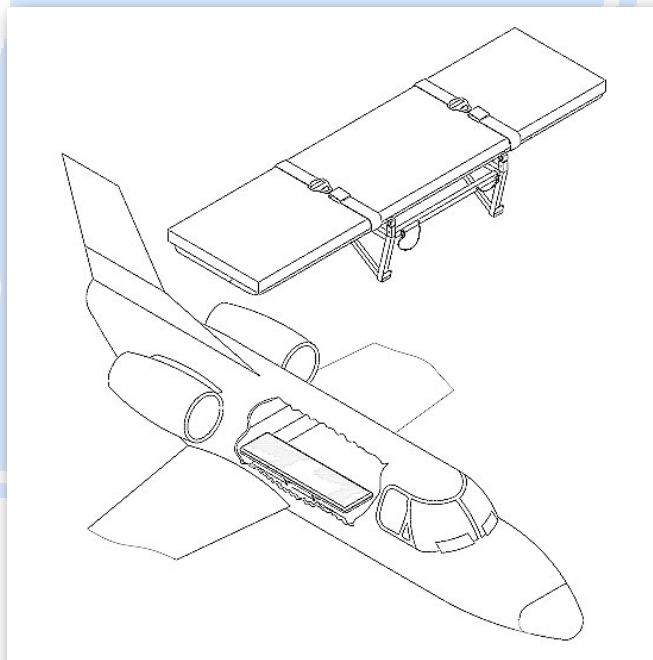



Citation 1, 2, & 3-Place Attendant Seating 500, 550, 560, & 650 Series

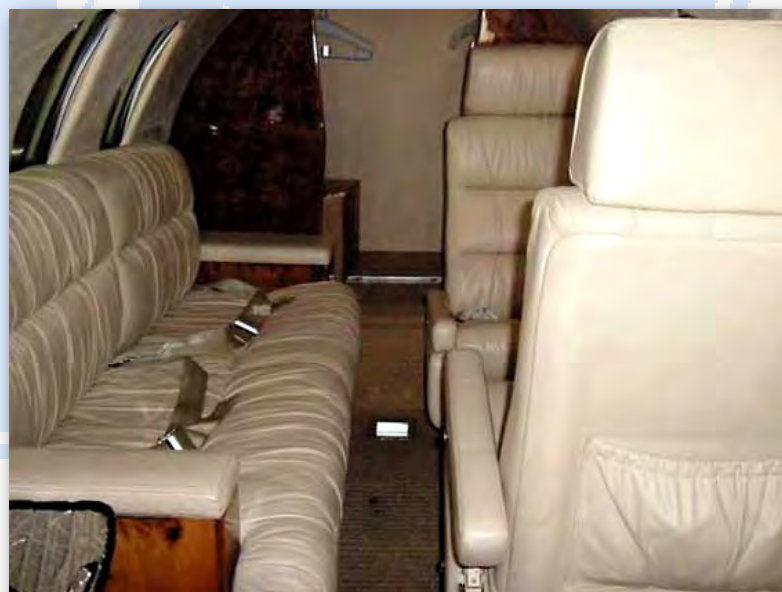



Citation 1, 2, & 3-Place Attendant Seating 500, 550, 560, & 650 Series

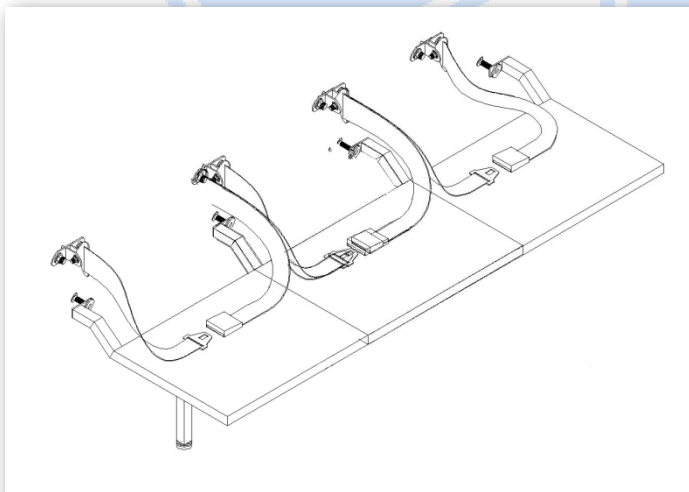
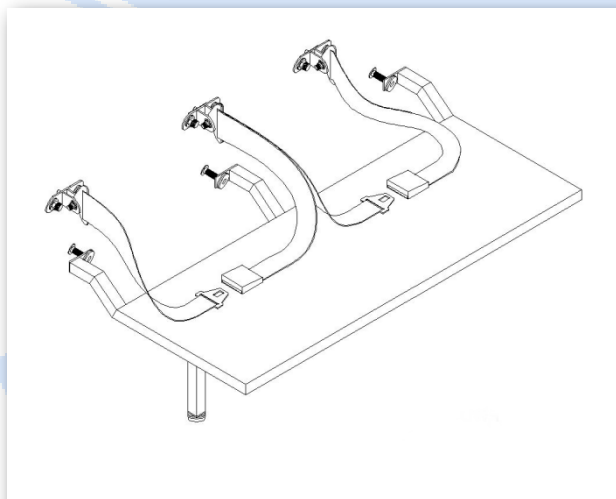
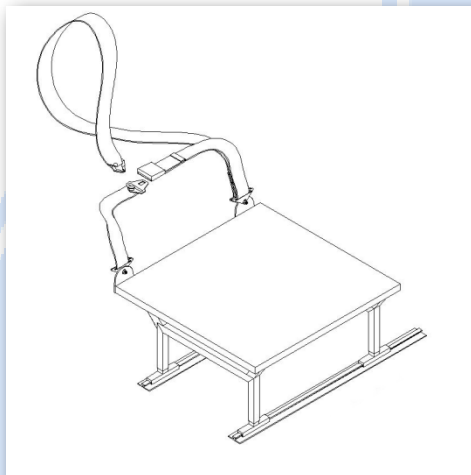



C208 Caravan Stretcher





C208 Caravan Stretcher

Description: The stretcher kit provides a Cessna C208 Caravan operator with the option of transporting an ill or non-critical patient. The kit was designed as an economical alternative to complete medevac systems. This unit is ideal for those operators who don't need critical care medical equipment.

Models: Cessna Caravan C208

FAA / STC: SA2847CE

This approval is applicable only to Cessna 208, 208A, and 208B cargo airplanes that have a right hand cabin entry door or the Cessna kits installed to permit opening the left hand cargo door from inside the cabin.

Approval: Federal Aviation Administration Parts Manufacture Approval, PMA, and Supplemental Type Certificate, STC, (eliminating the need for field approval).

Features: Kit includes stretcher base and cover, portable litter, mattress, mattress cover (conforms to FAR 23.853 horizontal flame test), restraint system, installation instructions, and weight and balance data, etc.

Installation: Initial installation can be accomplished by simply removing the seats on the applicable side of the aircraft and sliding the stretcher on existing seat rails.



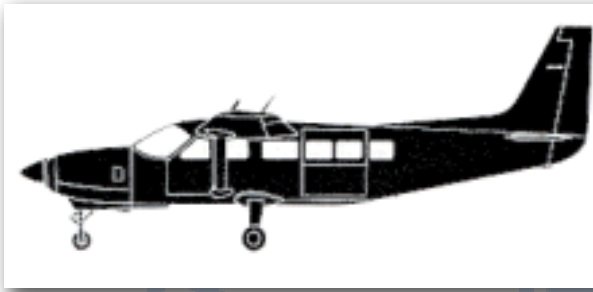

C208 Caravan Stretcher

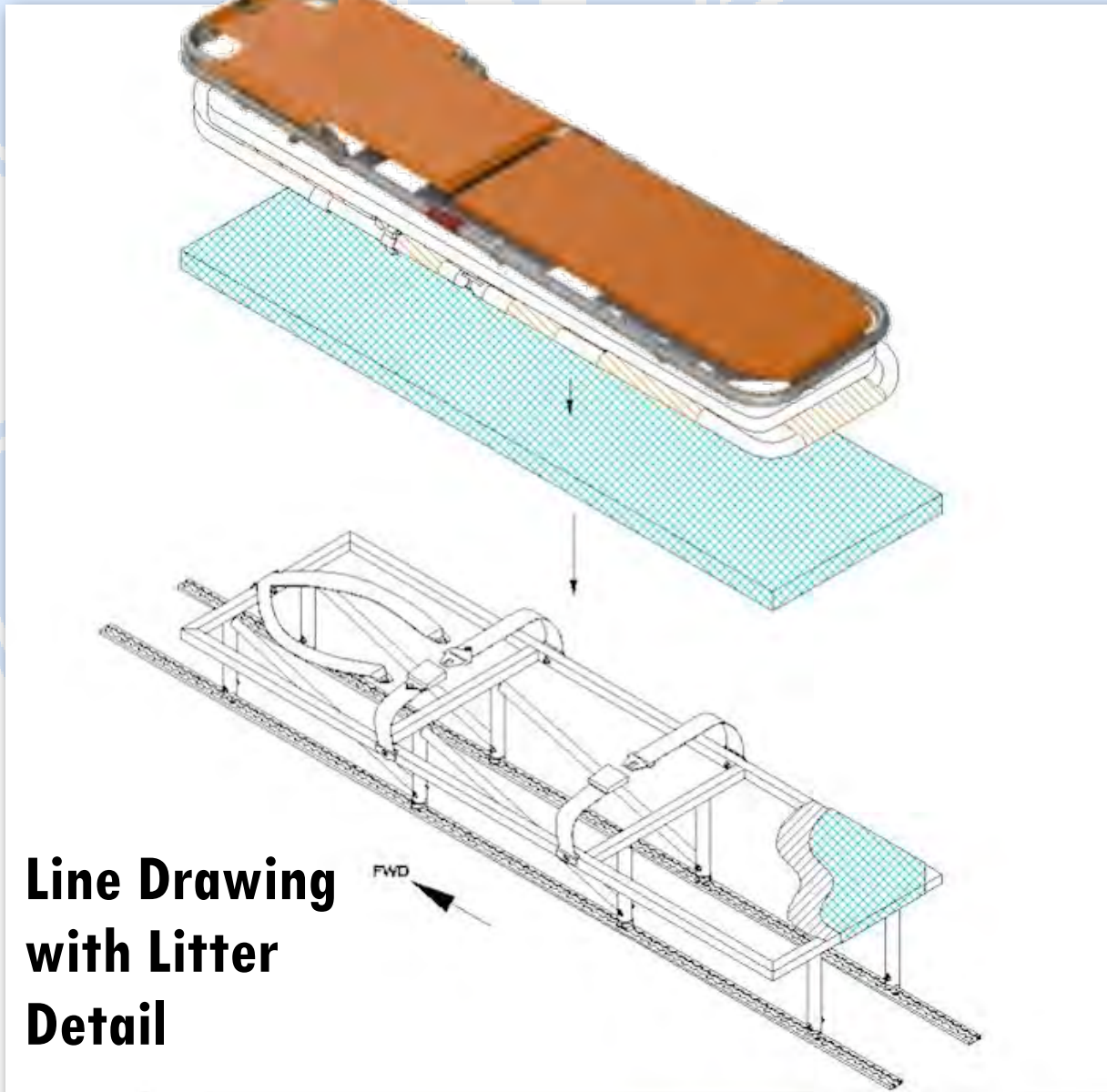

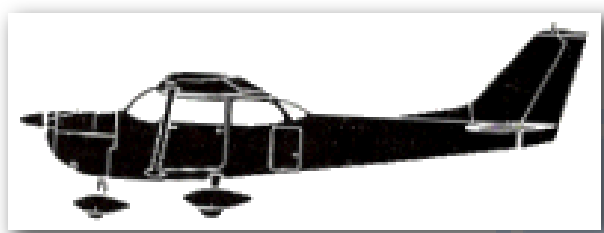

C172 - C210 Stretcher

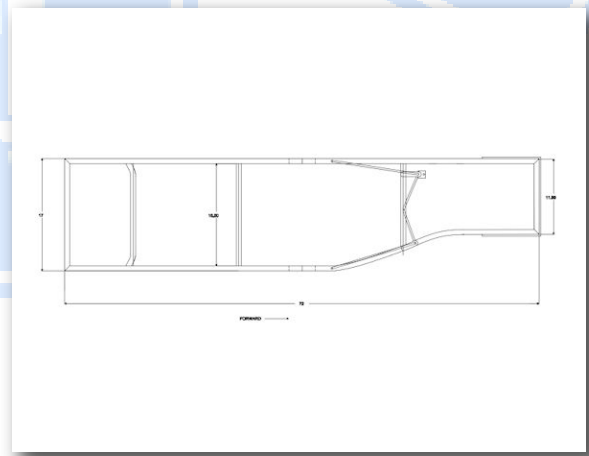
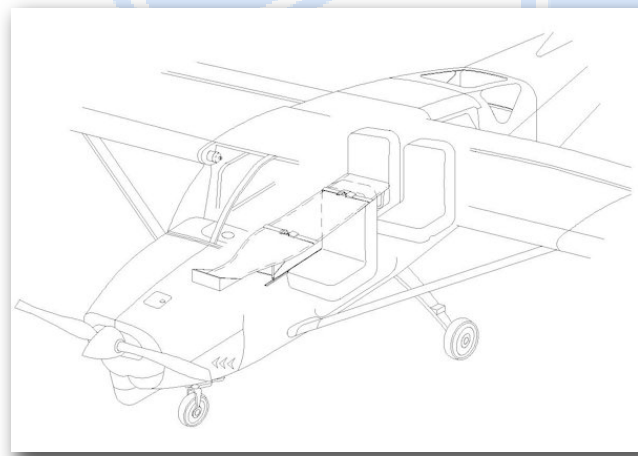



Learn more about Avfab's comprehensive
line of products & services at:

www.AvFab.com



Aviation Fabricators

805 North Forth Street

Clinton, MO 64735

(660) 885-8317

www.AvFab.com

